

Fly Torq

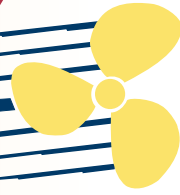

Propellers



committed to quality

Our Commitment to Quality...

HyTorq

Propellers

Hall & Stavert has been producing propellers and related marine hardware for most of its 63 year history. The original HyTorq Propeller line-up consisted primarily of a few sizes of 3-blade propellers. Today, the HyTorq line-up stands as one of the most complete propeller lines available to the marine industry. Whether for recreational or commercial use, vessel owners/operators can choose 3, 4 or 5-bladed HyTorq Propellers in most diameters from 17" to 48". Hall & Stavert's goal is to supply high quality, reliable propellers with the ability to perform consistently under today's vigorous conditions.

Our Commitment to Quality begins long before the receipt of your order. Our raw materials are inspected and certified prior to acceptance and our personnel complete extensive training programs prior to joining our permanent workforce. This combination ensures that HyTorq Propellers exhibit the quality, value and dependability that has become not only the standard for this product but also for the entire propeller industry.

Hall & Stavert's sales and engineering personnel will welcome any propeller sizing analysis requests and return our complete computer results as quickly as possible. All you need to do is send your completed propeller analysis form direct to us or contact one of our many HyTorq Propeller Distributors. Complete distributor listings and other HyTorq information can be obtained by contacting our website at www.hytorg.com

HyTorq MY-T3

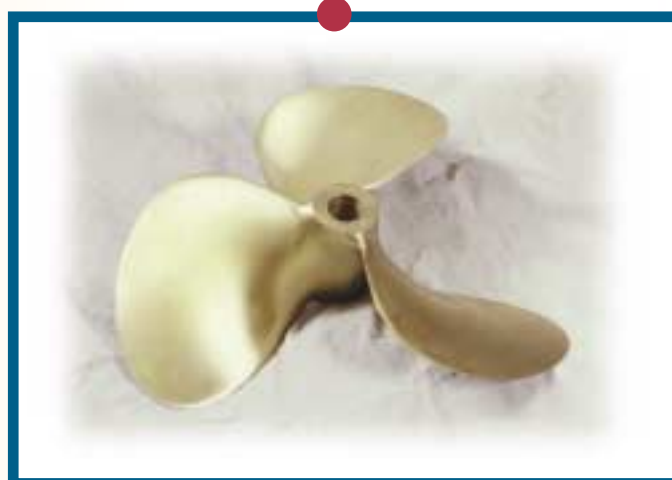

Hardworking commercial and high speed pleasure craft have one thing in common... their need for dependable performance from their propellers. The Hytorq MY-T3 is a propeller designed with both the hard working fishing boat and pleasure craft captains in mind. Designed to handle today's high powered engines with ease... the MY-T3 has a large blade area to enhance performance and maneuverability. The blades are carefully engineered, polished and finely profiled to allow increased thickness for greater strength in critical areas, without detracting from performance.

HyTorq MY-T4

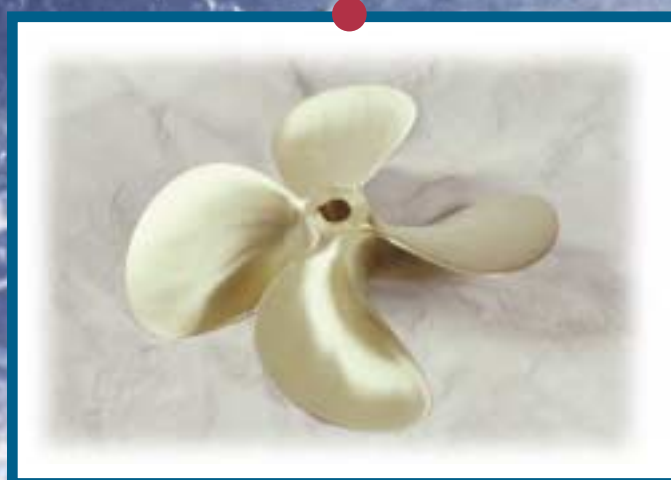

Manufactured to the same high quality standards as the three blade HyTorq, the four blade HyTorq is the right choice where either or both greater blade area and super smooth operation are desired. The HyTorq MY-T4 was designed with today's high powered engines in mind and built to the exacting standards that make it "The Captain's Choice" whether they are boating for profit or pleasure. The HyTorq hubs are designed to have the correct lengths required for more taper contact and better load distribution along with large outside diameters streamlined for smooth water flow while accommodating the popular larger shafts.

HyTorq MY-T5



Like all HyTorq models, the MY-T5 is manufactured to the high quality standards of Hall & Stavert. Dimensional Tolerance conformance is exceeded only by Hall & Stavert's customized computer machined models, made to military standards but seldom required by even the highest performance pleasure and commercial boats. For a number of reasons, many operators are selecting HyTorq model MY-T5 five bladed propellers for new construction, repowering, and propeller upgrading. The main reason is to employ more blade area without having to increase propeller diameter, which may not be possible due to clearance or tip speed considerations. Another common reason is to improve performance of the propeller in installations where heavy Vee struts, dead wood, or other hull appendages are agitating the water flow to the propeller. In some instances where vibration due to resonance is a problem, a five blade HyTorq is just the answer.

HyTorq Customs



As encountered in some engineering applications, there are times when the standard product line does not do the job. Propeller applications are no different. For these situations, Hall & Stavert offers a complete custom design and manufacturing service. Whether or not your resulting propeller is CNC Machined or of our standard high quality hand finish, we will ensure that you have a propeller that suits your requirement.



METALLURGY

The manganese bronze alloy is the standard “HyTorq” propeller metal. With a minimum tensile strength of 65,000 psi, this alloy guarantees a propeller that is dimensionally stable and easily repaired.

Where exceptional strength and durability are required, our nickel aluminum bronze may be the best. This alloy, with a minimum tensile strength of 85,000 psi, provides excellent resistance to corrosion and cavitation erosion.

All HyTorq Propellers are available in the popular sizes in both manganese bronze and nickel aluminum bronze.

SPECIFICATIONS

HyTorq MY-T3

Propeller Diameter	Aft Hub Diameter	Fwd Hub Diameter	Hub Length*	Maximum Bore	Minimum Bore	Pilot Taper	Weight (lbs)**	Developed Area (in ²)	WR ² ***
17"	2-1/4	2-1/2	3-1/2	1-1/2	1-1/4	1-1/4	16	126.6	333
18"	2-3/8	2-5/8	3-1/2	1-3/4	1-1/4	1-1/4	17	141.9	392
19"	2-3/8	2-5/8	3-7/8	1-3/4	1-1/4	1-1/4	19	166.2	478
20"	2-3/8	2-5/8	4	1-3/4	1-1/4	1-1/4	21	175.3	553
21"	2-3/4	3	4-1/8	2	1-3/8	1-3/8	27	202.4	680
22"	2-3/4	3	4-1/4	2	1-3/8	1-3/8	30	212.1	810
23"	3-1/8	3-1/4	4-1/4	2	1-1/2	1-3/8	35	240.6	1070
24"	3-1/8	3-1/4	4-5/8	2	1-1/2	1-3/8	35	252.4	1220
26"	3-3/8	3-5/8	5	2-1/4	1-3/4	1-1/2	50	296.3	1770
28"	3-3/4	4	5-3/4	2-1/2	1 3/4	1-3/4	57	343.6	2630
30"	4	4-1/4	6	2-3/4	1-3/4	1-3/4	78	394.4	3520
32"	4-1/4	4-1/2	6	3	2	2	94	448.8	4810
34"	4-1/4	4-1/2	6-1/2	3	2	2	107	506.6	6460
36"	4-3/4	5-1/4	8-1/4	3-1/2	2-3/4	2-1/2	130	567.7	8910

All dimensions are in inches

* denotes approx. dimensions only

** denotes approx. weight - Manganese Bronze

*** denotes approx. WR² in air

HyTorq MY-T4

Propeller Diameter	Aft Hub Diameter	Fwd Hub Diameter	Hub Length*	Maximum Bore	Minimum Bore	Pilot Taper	Weight (lbs)**	Developed Area (in ²)	WR ² ***
17"	2-1/4	2-1/2	3-1/2	1-1/2	1-1/4	1-1/4	19	153.1	366
18"	2-3/8	2-5/8	3-1/2	1-3/4	1-1/4	1-1/4	19	171.7	429
19"	2-3/8	2-5/8	3-7/8	1-3/4	1-1/4	1-1/4	21	202.7	499
20"	2-3/8	2-5/8	4	1-3/4	1-1/4	1-1/4	23	212.1	622
21"	2-3/4	3	4-1/8	2	1-3/8	1-3/8	28	238.6	790
22"	2-3/4	3	4-1/4	2	1-3/8	1-3/8	31	256.9	940
23"	3-1/8	3-1/4	4-1/4	2	1-1/2	1-3/8	39	288.4	1300
24"	3-1/8	3-1/4	4-5/8	2	1-1/2	1-3/8	41	305.4	1450
26"	3-3/8	3-5/8	5	2-1/4	1-3/4	1-1/2	53	358.4	2150
28"	3-3/4	4	5-3/4	2-1/2	1 3/4	1-3/4	66	415.6	3240
30"	4	4-1/4	6	2-3/4	1-3/4	1-3/4	82	477.1	4230
32"	4-1/4	4-1/2	6	3	2	1-3/4	100	542.9	5960
34"	4-1/4	4-1/2	6-1/2	3	2	2	140	612.8	8020
36"	4-3/4	5-1/4	8-1/4	3-1/2	2-3/4	2-1/2	146	686.7	11230
38"	5-1/4	5-1/2	8-1/4	3-1/2	2-3/4	2-1/2	172	765.2	13750
40"	5-1/4	5-1/2	9	3-3/4	3	3	192	847.8	17180
42"	5-1/2	6	10-1/2	4	3	3	240	935.0	24400
44"	5-1/2	6-1/4	10-1/2	4	3	3	282	1025.8	31500
46"	5-1/2	6-1/4	10-1/2	4	3	3	304	1121	37000
48"	5-1/2	6-1/4	10-1/2	4	3	3	340	1221	45800

All dimensions are in inches

* denotes approx. dimensions only

** denotes approx. weight - Manganese Bronze

*** denotes approx. WR² in air

HyTorq MY-T5

Propeller Diameter	Aft Hub Diameter	Fwd Hub Diameter	Hub Length*	Maximum Bore	Minimum Bore	Pilot Taper	Weight (lbs)**	Developed Area (in ²)	WR ² ***
24"	3-1/8	3-1/4	4-5/8	2	1-1/2	1-3/8	57	384	1990
26"	3-3/8	3-5/8	5	2-1/4	1-3/4	1-1/2	72	451	3115
28"	3-3/4	4	5-3/4	2-1/2	1 3/4	1-3/4	79	523	4967
30"	4	4-1/4	6	2-3/4	1-3/4	1-3/4	109	601	6480
32"	4-1/4	4-1/2	6	3	2	1-3/4	150	683	8847
34"	4-1/4	4-1/2	6-1/2	3	2	2	180	772	11985
36"	4-3/4	5-1/4	8-1/4	3-1/2	2-3/4	2-1/2	210	864	15676
38"	5-1/4	5-1/2	8-1/4	3-1/2	2-3/4	2-1/2	240	964	19961
40"	5-1/4	5-1/2	9	3-3/4	3	3	260	1068	23961
42"	5-1/2	6	10-1/2	4	3	3	325	1177	33022
44"	5-1/2	6	10-1/2	4	3	3	370	1291	41260
46"	5-1/2	6-1/4	10-1/2	4	3	3	410	1412	49975

All dimensions are in inches

* denotes approx. dimensions only

** denotes approx. weight - Manganese Bronze

*** denotes approx. WR² in air

Propeller Shaft and Hub Bore Dimensions

To ensure interchangeability, finish bore propellers are machined to the S.A.E. standards as given below. Pilot bore propellers must be finish bored with reference to the pilot bore rather than the hub or blade tips.

Propeller Shaft End Dimensions Taper = 3/4 in. on diameter per foot

Shaft Dia. $\frac{1}{4}$ "	Shaft Dia. Small End $\frac{1}{8}$ "	Taper Length $\frac{1}{4}$ "	Keyway $\frac{1}{4}$ " Width $\frac{1}{8}$ "	Keyway $\frac{1}{2}$ " Width $\frac{1}{8}$ "	Thread Dia. $\frac{1}{4}$ "	Threads Per Inch	End Taper To End Thread $\frac{1}{8}$ "	Ext. Beyond Taper $\frac{1}{4}$ "	Undercut $\frac{1}{4}$ "	Undercut $\frac{1}{2}$ "	Dia. of Pin End $\frac{1}{4}$ "	Length of Pin End $\frac{1}{4}$ "	Cotter Pin Hole $\frac{1}{4}$ "	Cotter Pin Drill $\frac{1}{4}$ "	Cotter Pin Dia.	Cotter Pin Length	Keyway Length $\frac{1}{4}$ "
3/4	.625	2	3/16	3/32	1/2	13	1-1/16	1-5/16	25/64	1/8	3/8	1/4	1-9/64	9/64	1/8	3/4	1-1/2
7/8	.727	2-3/8	1/4	1/8	5/8	11	1-1/4	1-1/2	31/64	1/8	7/16	1/4	1-21/64	9/64	1/8	3/4	1-25/32
1	.828	2-3/4	1/4	1/8	3/4	10	1-7/16	1-3/4	19/32	1/8	1/2	5/16	1-33/64	9/64	1/8	1	2-1/8
1-1/8	.930	3-1/8	1/4	1/8	3/4	10	1-7/16	1-3/4	19/32	1/8	1/2	5/16	1-33/64	9/64	1/8	1	2-1/8
1-1/4	1.031	3-1/2	5/16	5/32	7/8	9	1-5/8	2	23/32	1/8	5/8	3/8	1-23/32	11/64	5/32	1-1/4	2-13/16
1-3/8	1.133	3-7/8	5/16	5/32	1	8	1-13/16	2-1/4	13/16	1/8	3/4	7/16	1-29/32	11/64	5/32	1-1/2	3-3/16
1-1/2	1.234	4-1/4	3/8	3/16	1-1/8	7	2	2-7/16	29/32	3/16	7/8	7/16	2-3/32	11/64	5/32	1-1/2	3-1/2
1-3/4	1.438	5	7/16	7/32	1-1/4	7	2-1/4	2-3/4	1-1/32	3/16	1	1/2	2-23/64	13/64	3/16	1-3/4	4-7/32
2	1.641	5-3/4	1/2	1/4	1-1/2	6	2-5/8	3-1/8	1-1/4	3/16	1-1/4	1/2	2-47/64	13/64	3/16	2	4-15/16
2-1/4	1.844	6-1/2	9/16	9/32	1-3/4	5	3	3-1/2	1-3/8	3/16	1-3/8	1/2	3-9/64	17/64	1/4	2-1/4	5-5/8
2-1/2	2.047	7-1/4	5/8	5/16	1-3/4	5	3	3-1/2	1-7/16	3/16	1-7/16	1/2	3-9/64	17/64	1/4	2-1/4	6-3/32
2-3/4	2.258	7-7/8	5/8	5/16	2	4-1/2	3-1/2	4	1-11/16	1/4	1-11/16	1/2	3-41/64	17/64	1/4	2-1/2	6-21/32
3	2.461	8-5/8	3/4	5/16	2-1/4	4-1/2	3-7/8	4-3/8	1-15/16	1/4	1-15/16	1/2	4-1/64	17/64	1/4	3	7-11/32
3-1/4	2.664	9-3/8	3/4	5/16	2-1/2	4	4-3/8	5-1/8	2-1/8	3/8	2-1/8	3/4	4-37/64	3/8	3/8	3	8-1/2
3-1/2	2.867	10-1/8	7/8	5/16	2-1/2	4	4-3/8	5-1/8	2-1/8	3/8	2-1/8	3/4	4-37/64	3/8	3/8	3	9-1/4
3-3/4	3.070	10-7/8	7/8	5/16	2-3/4	4	4-3/4	5-1/2	2-3/8	3/8	2-3/8	3/4	4-61/64	3/8	3/8	3-1/2	10
4	3.273	11-5/8	1	5/16	3	4	5-1/8	5-7/8	2-1/2	3/8	2-1/2	3/4	5-21/64	3/8	3/8	3/8	10-1/2

* Keyway shall be cut parallel to taper

All dimensions are in inches

Propeller Hub Bore Dimensions

Taper = 3/4 in. on diameter per foot

	Standard Taper		Dia. Small End $\frac{1}{8}$ "		Keyway $\frac{1}{4}$ " Width $\frac{1}{8}$ "		Keyway $\frac{1}{2}$ " Depth $\frac{1}{4}$ "	
	Min	Max	Nom	Min	Max	Nom	Min	Max
3/4	.608	.610	3/16	.1865	.1875	3/32	.098	.100
7/8	.710	.712	1/4	.249	.250	1/8	.129	.131
1	.811	.813	1/4	.249	.250	1/8	.129	.131
1-1/8	.913	.915	1/4	.249	.250	1/8	.129	.131
1-1/4	1.015	1.017	5/16	.3115	.3125	5/32	.162	.165
1-3/8	1.116	1.118	5/16	.3115	.3125	5/32	.161	.164
1-1/2	1.218	1.220	3/8	.374	.375	3/16	.195	.198
1-3/4	1.421	1.423	7/16	.4365	.4375	7/32	.226	.229
2	1.624	1.626	1/2	.499	.500	1/4	.259	.262
2-1/4	1.827	1.829	9/16	.561	.5625	9/32	.291	.294
2-1/2	2.030	2.032	5/8	.6235	.625	5/16	.322	.325
2-3/4	2.233	2.235	5/8	.6235	.625	5/16	.322	.325
3	2.437	2.439	3/4	.7485	.750	5/16	.323	.326
3-1/4	2.640	2.642	3/4	.7485	.750	5/16	.323	.326
3-1/2	2.843	2.845	7/8	.8735	.875	5/16	.324	.327
3-3/4	3.046	3.048	7/8	.8735	.875	5/16	.324	.327
4	3.249	3.251	1	.9985	1.000	5/16	.326	.329

* Keyway shall be cut parallel to taper

* Keyway side depth is measured normal to axis of taper

All dimensions are in inches

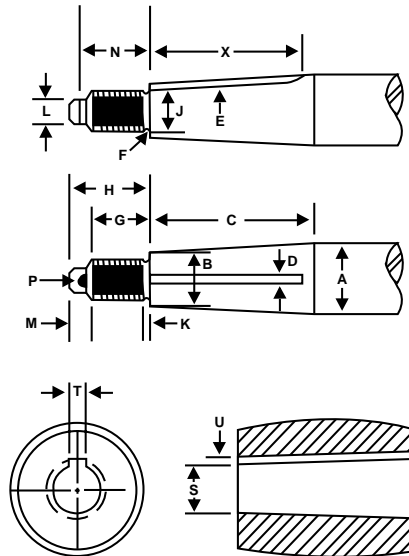

Hall & Stavert

22 McCarville St., West Royalty Industrial Park, Charlottetown, Prince Edward Island, Canada C1E 2A6
 Phone (902) 566-3335 Fax (902) 566-9258
 Web Site: www.hyorq.com Email Address: hytorq@hytorq.com

